

## **Tool Box Pencil Kits Assembly Instructions**

### **Required Accessories**

- 7mm pen mandrel
- 3 pc bushing set RZ-PCL73#-BU
- 11mm drill bit
- Universal pen blank squaring jig or disc/belt sander
- 2-part epoxy glue or insta-cure (cyano acrylate) glue

### **Preparing the Blank**

- Cut 3/4" to 5/8" square blanks to the length of the brass tubes (add 1/16" for squaring off)
- Drill a 11mm center hole lengthwise through each blank.
- Spread glue over the tubes and insert each tube into the blank with a twisting motion to spread the glue evenly inside. Center each tube lengthwise in the blank.

**Note:** The lower tube is threaded inside. To prevent glue from spreading inside the tube onto the thread, you must plug the opening before gluing. You can use a potato slice or any other suitable material to plug the hole.

- When the glue dries, square the ends of the blanks. Use a universal pen blank squaring jig or a belt / disc sander, or wrap masking tape around the shaft of your barrel trimmer to square the

ends.

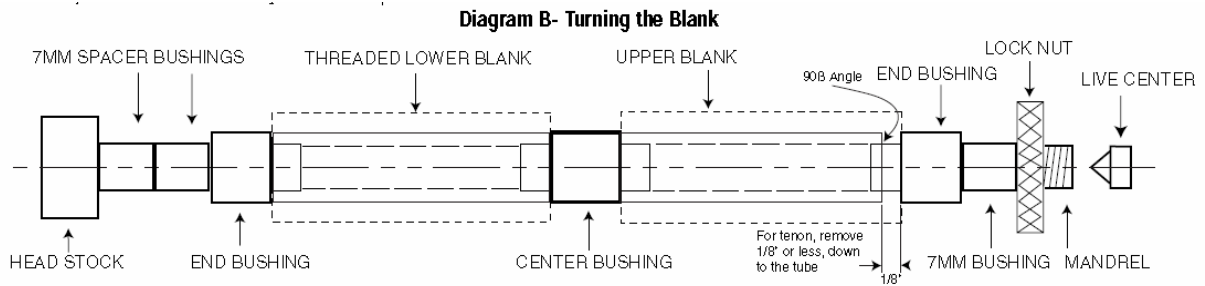

## Turning the Blank

- Place a 7mm spacer bushing onto the mandrel. Follow with an end bushing, wide end on first. Slip the threaded lower blank on and place the center bushing on next. Follow with the upper blank, then the end bushing, narrow end first. Insert a spacer bushing to close the space to the thread. Thread on the knurled nut and hand tighten. Slide the tail stock snug to the mandrel shaft (do not over tighten, it will damage the mandrel), lock in place.

Snugly tighten the knurled nut to avoid spinning the blanks.

- Turn the wood down, flush with the bushings, using lathe chisels and gradual higher grits of abrasives. Finish the wood with friction polish for a brilliant finish.

## Cutting a Tenon

- Pencil mark 1/8" or less at the upper blank (see Diagram B) use a tenon cutting tool to remove the wood down to the brass tube. Make sure to leave a sharp 90° corner.

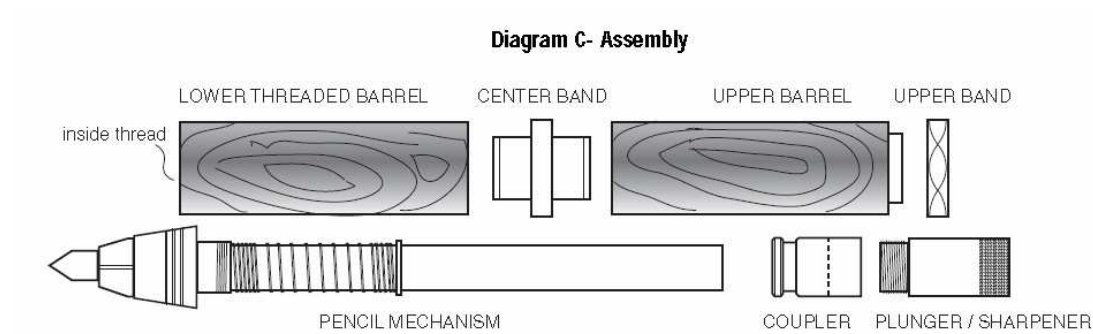

## Assembly Tips

- Line up finished parts according to Diagram C
- To press parts in, use pen press, or a vise with covered jaws. Press parts slowly to avoid scratching and damaging the compone

## Assembly

- Press the center band extension into the lower barrel.

**Note:** press into the opposite end of the threaded side.

- Press the center band into the end of the upper barrel, opposite the tenon.

- Press the six-sided upper band over the recess/tenon. Insert the pencil mechanism into the opening at the lower barrel. Thread into place.

- Screw the plunger / eraser into the coupler. Carefully, squeeze a drop of cyanoacrylate into the opening of the coupler and quickly insert this assembly

through the top end, over the pencil mechanism inside.

- To sharpen the lead, unscrew the plunger and insert over the lead and turn lightly.

- To replace the lead with the magic lead, depress the plunger to pull lead out and replace.