

Trædrejerbutikken

New Seam Ripper kits Assembly Instructions

Required Accessories

- 7mm, Pen Mandrel
- 8mm Drill Bit RZ-DB008
- 8mm Barrel Trimmer RZ-PM012
- 2 pcs Bushings Set RZ-PK91#-BU
- Glue (Thick CA or Epoxy)

Diagram A



Preparing the Blank

- Prepare and cut a blank of 3/4" or larger, to the length of the brass tube (add 1/16" for trimming)
- Drill a 8mm hole through the center of the blank.
- Spread glue over the tube, insert into blank with a twisting motion to spread the glue evenly inside.
- Center the tube inside the blank.
- When glue is dry. Trim the ends of the blank flush to the tube.

Diagram B - Turning the Blank

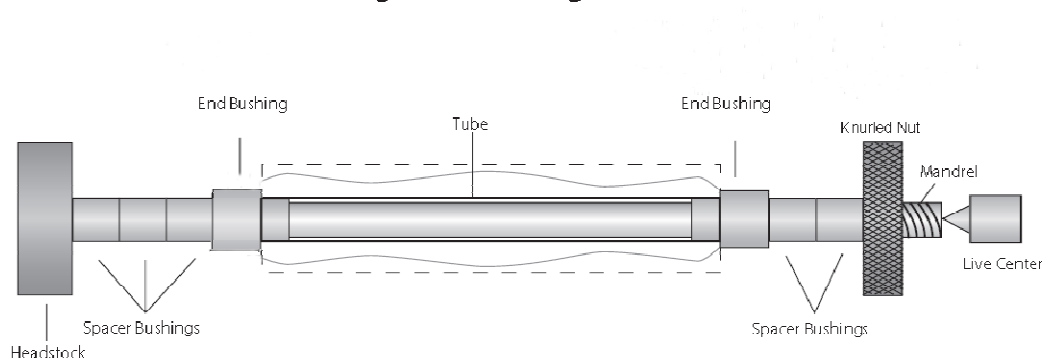

Turning the Blank

- Place the bushings and blank on the mandrel according to Diagram B.
- Thread on the knurled nut and hand tighten to hold all items in place.
- Slide the tailstock to the mandrel shaft, (do not overtighten, it could damage the mandrel) lock in place.
- Turn the handle ends down, flush with the bushings using the lathe tools, gradually increasing the grades of sand paper.
- Finish the wood with friction polish .

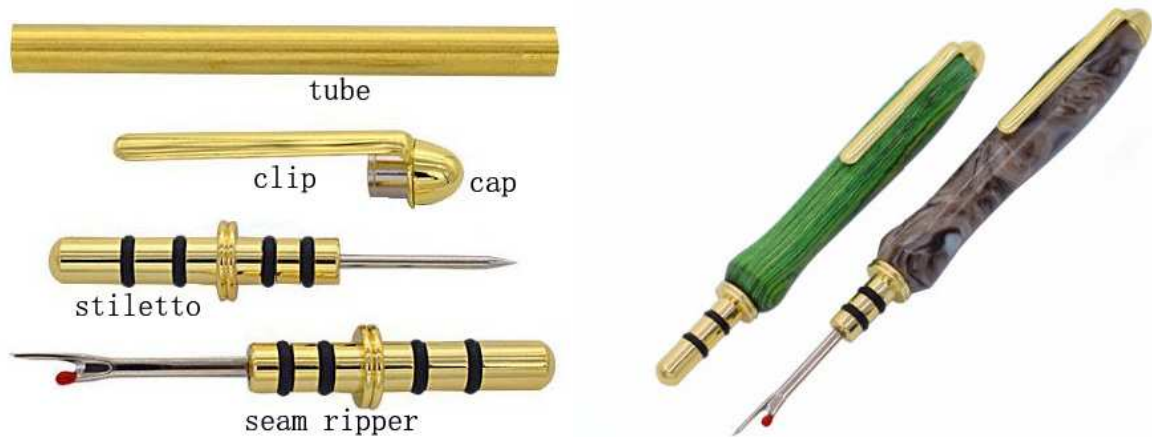

Assembly

- Press the clip to one end of the tube.
- Slide the seam ripper assembly in and out with both ends to assure a secure fit.
- When not in use, reverse the ripper assembly to safely store the blade(s).